

THE DESIGN CONCEPTS AND INFORMATION CONTAINED HEREIN ARE PROPRIETARY TO OPTI-FORMS, INC. AND MAY NOT BE CONVEYED TO THIRD PARTIES WITHOUT EXPRESS WRITTEN CONSENT.

NOTES: (UNLESS OTHERWISE SPECIFIED)

- SPECIFICATION CONTROL DRAWING.
- DEBURR SHARP EDGES .015 MAX.

3 REFLECTOR TO BE REPLICATED FROM SPECIFIED MASTER TOOL EXHIBITING REQUIRED ELLIPTICAL GEOMETRY AND SPECULAR SURFACE FINISH OF 80-50 SCRATCH-DIG PER MIL-O-13830A.

4 NOMINAL THICKNESS T MAY VARY $\pm T/4$ WITHIN .25 OF EDGES.

5 VERTEX HOLE OPENING IS PREFERRED REGISTRATION FEATURE FOR AXIAL ALIGNMENT OF REFLECTOR. PLANE OF CLEAR APERTURE NOT RECOMMENDED FOR THIS PURPOSE.

6 FINAL REFLECTIVE SURFACE CONDITION WITH AVAILABLE REFLECTIVITY ENHANCEMENT COATINGS DEFINED AS FOLLOWS: (ADD DESIGNATED SUFFIX TO P/N)

- RH ELECTRO-DEPOSITED BRIGHT RHODIUM
- AQ VACUUM DEPOSITED ALUMINUM WITH SiO₂ (QUARTZ)
- AF VACUUM DEPOSITED ALUMINUM WITH MgF₂ (MAGNESIUM FLUORIDE)
- DCC DICHOIC COLD COATING - SPECIFY WAVELENGTH REGION
- SP OTHER SPECIAL COATINGS AS SPECIFIED

REVISIONS				
ZONE	REV	DESCRIPTION	DATE	APPROVED
	A	REVISED DIM TOL	02-05-98	KEN S
	B	REVISED TOLERANCES	06-30-98	KEN S
	C	CORRECTED GEOMETRY DATA	03-17-00	GFW /

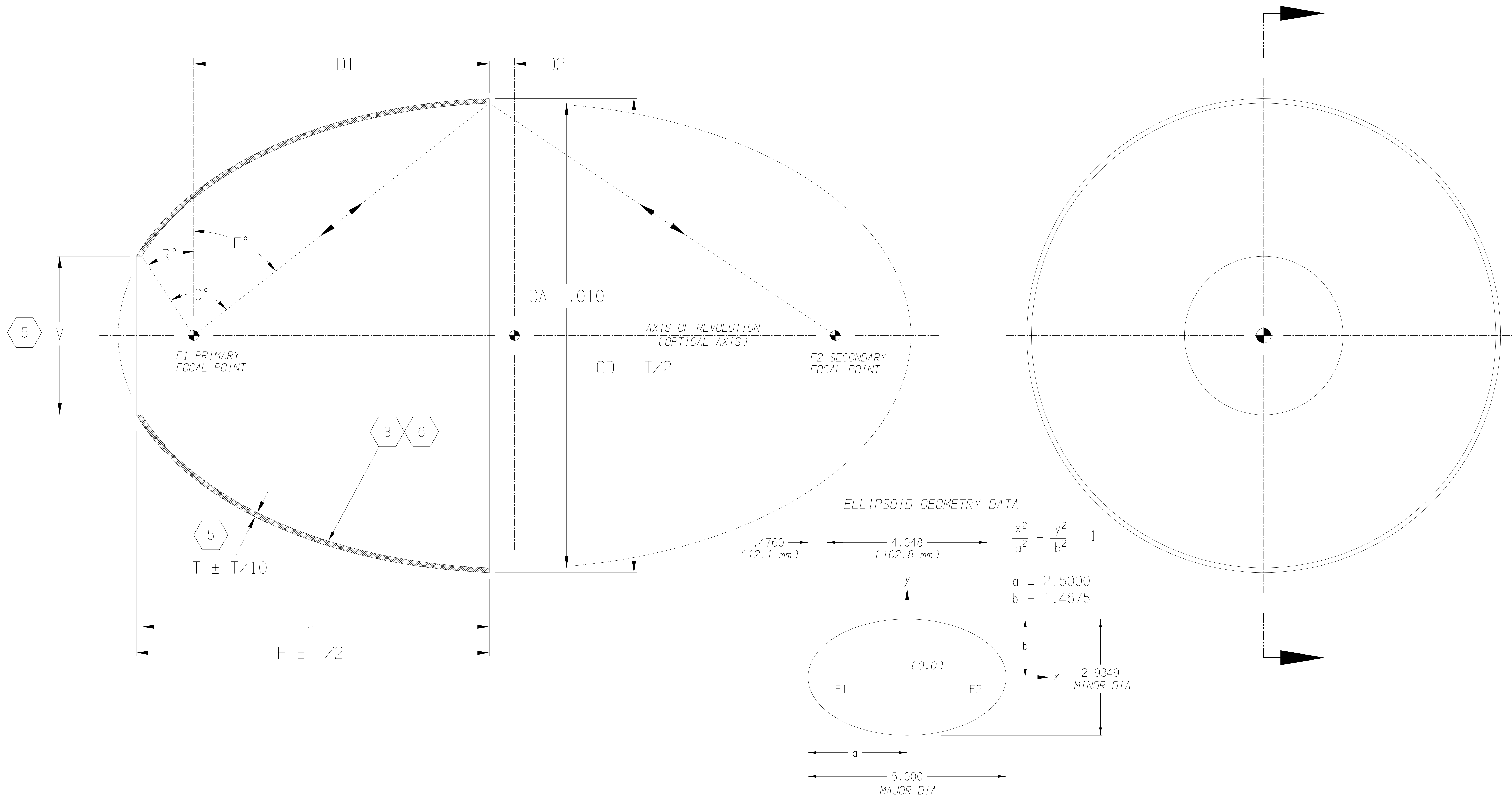

-3	Ø2.726	Ø1.000	Ø2.788	.030	1.098	.926	1.459	1.424	33.14°	38.84°	71.98°	1.19
-2	Ø2.929	Ø.500	Ø2.989	.030	1.865	.159	2.336	2.305	60.36°	51.87°	112.23°	.90
-1	Ø2.929	Ø1.000	Ø2.989	.030	1.865	.159	2.227	2.192	33.14°	51.86°	85.00°	.90
DASH NO.	CA	V	OD	T	D1	D2	H	h	R°	F°	C°	f#

UNLESS OTHERWISE SPECIFIED DIMENSIONS ARE IN INCHES TOLERANCES ARE:

FRACTIONS ± 1/16	DECIMALS .XX ± .02 .XXX ± .005	ANGLES ± 1/2°
------------------	--------------------------------	---------------

63 ✓

CONTRACT NO. 96-E103

APPROVALS: DRAWN GFW, CHECKED MJB, ENGR, DESIGN ACTIVITY

DATE: 05-31-95

MATERIAL: ELECTROFORMED NICKEL LSSN OF I TYPE I

FINISH: NOTES 3,6

SCALE: N/A

SIZE: C

CAGE CODE: OY1Y4

DWG NO: E103

REV: C

ITEM NO: 92590

REFLECTOR, ELLIPTICAL 4.05" / 103mm (F1-F2)

SCALE: N/A E103-R.PRT SHEET 1 OF 1

SPEC CONTROL DWG

APPLICATION	DO NOT SCALE DRAWING
NEXT ASSY	USED ON