

NOTES: UNLESS OTHERWISE SPECIFIED

- 1 ELECTROFORM REFLECTOR FROM MASTER TOOL WITH SPECULAR SURFACE QUALITY OF 80-50 SCRATCH-DIG PER MIL-PRF-13830B.
- 2 NOMINAL THICKNESS (T) MAY VARY ± T/4 WITHIN .25 OF EDGES.
- 3 REFLECTIVE SURFACE COATING TO BE SEPARATELY SPECIFIED.

REVISIONS			
REV	DESCRIPTION	DATE	APPROVED
Ø	INITIAL DRAWING RELEASE	05/31/96	GFW
A	ADDED -3	08/26/97	KMT
B	REV DIM TOL	02/11/98	KMT
C	REVISED TOLERANCES	06/30/98	KEN S
D	0.45 WAS 0.40, 5.279 WAS 5.274, 5.209 WAS 5.203, 4.261 WAS 4.255	02/06/02	GFW
E	UPDATED DRAWING FORMAT	08/22/17	RRS

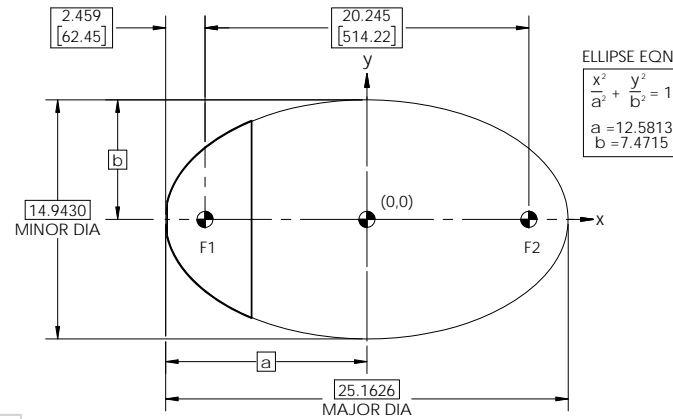
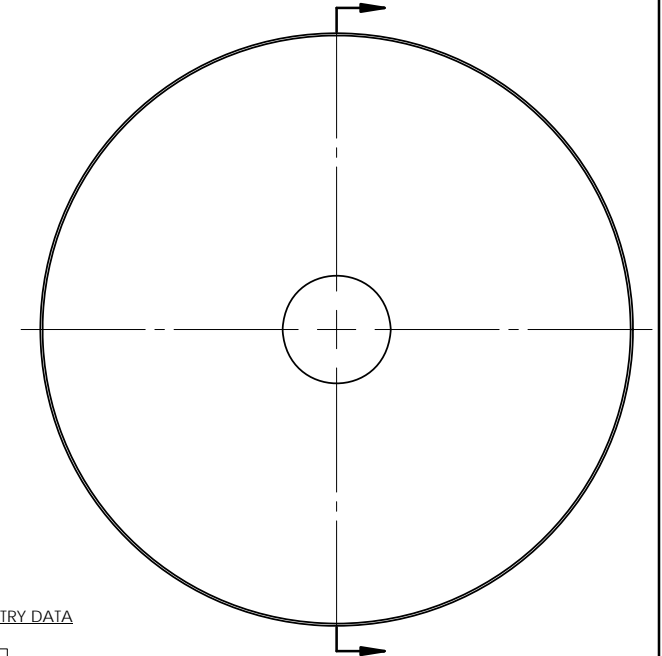
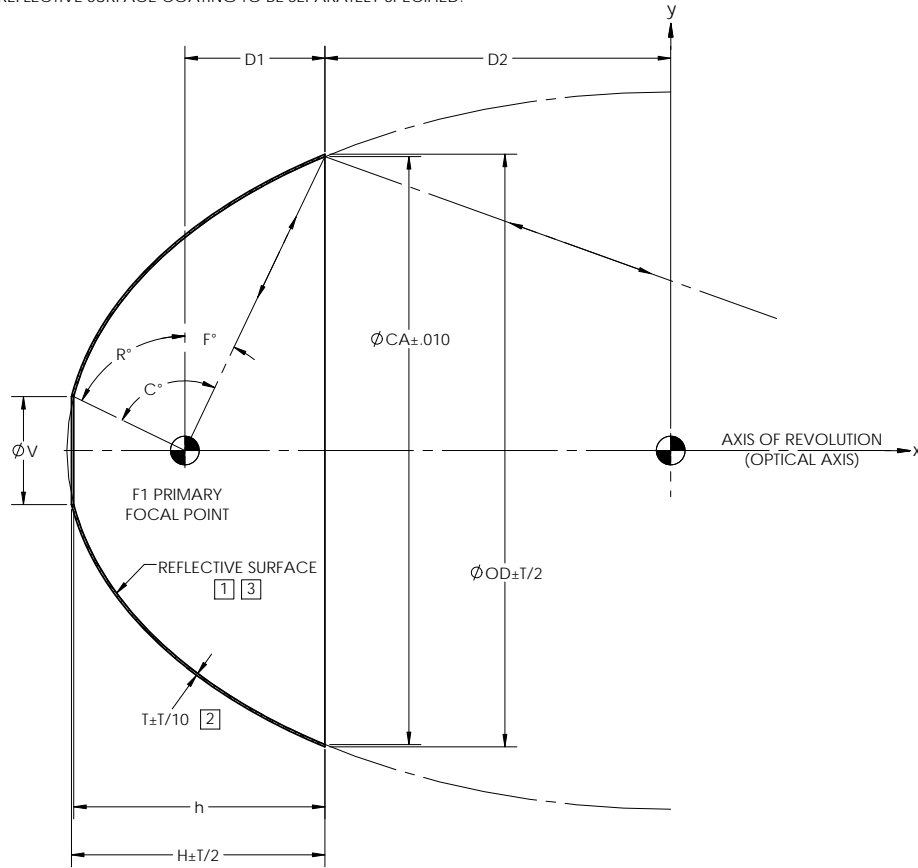

DASH NO.	CA	V	OD	T	D1	D2	H	h	R°	F°	C°	f#
E514	12.250	2.250	12.347	0.045	2.918	7.205	5.279	5.233	64.09	25.47	89.56	1.50
E514-0100	12.250	2.250	12.347	0.045	2.918	7.205	5.279	5.233	64.09	25.47	89.56	1.50
E514-0200	12.250	2.750	12.347	0.045	2.918	7.205	5.209	5.161	58.50	25.47	83.97	1.50
E514-0300	12.250	6.299	12.347	0.045	2.918	7.205	4.261	4.204	22.22	25.47	47.69	1.50

NOTE: THE "E514" DASH NO. IS THE THEORETICALLY LARGEST REFLECTOR THAT CAN BE FORMED FROM EXISTING MASTER TOOLING.

UNLESS OTHERWISE SPECIFIED DIMENSIONS ARE IN INCHES [mm] GD&T PER ASME Y14.5-2009 DO NOT SCALE DRAWING		CONTRACT NO. 96-E514		optiforms® 42310 WINCHESTER RD. TEMECULA, CA 92590 WWW.OPTIFORMS.COM	
FRACTIONS ± 1/16 DECIMALS ± .02 ANGLES ± 1/2° TOLERANCES XXX ± .005		DRAWN JIW	DATE 08/22/17	REFLECTOR, ELLIPTICAL 20.25"/514mm (F1-F2)	
SURFACE ROUGHNESS √ DEBURR SHARP EDGES & HOLES Ø.015 MAX. CHAMFER THREADS Ø1 PAST ROOT DIAMETER		CHECKED	DATE	SCALE 1:2	
NEXT ASSY		ENGR RRS	DATE 08/22/17	DWG. NO. E514	
USED ON		MATERIAL ELECTROFORMED NICKEL - LSSN TYPE 1		REV E	
APPLICATION		FINISH		SHEET 1 OF 1	
THIRD ANGLE PROJECTION		SEE NOTE 3		CAD NO. E514	