

INFORMATION IN THIS DRAWING IS FOR REFERENCE ONLY

REVISIONS			
REV	DESCRIPTION	DATE	APPROVED
Ø	INITIAL DRAWING RELEASE	09/21/16	JMK
A	UPDATED DRAWING	09/14/17	JPH

NOTES: UNLESS OTHERWISE SPECIFIED

- REFLECTOR SURFACE QUALITY: ELECTROFORM REFLECTOR FROM MASTER TOOL WITH SPECULAR SURFACE FINISH OF 80-50 SCRATCH-DIG PER MIL-O-13830A.
- MOUNT BONDED TO REFLECTOR USING EPOXY.
- REFLECTOR: ELECTROFORMED - NICKEL LSSN TYPE 1.
MOUNT: 6061-T6 ALUMINUM, BLACK ANODIZE FINISH.

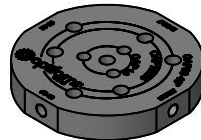
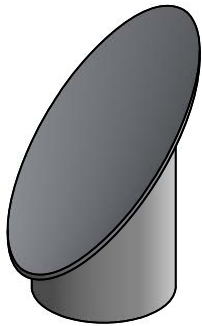
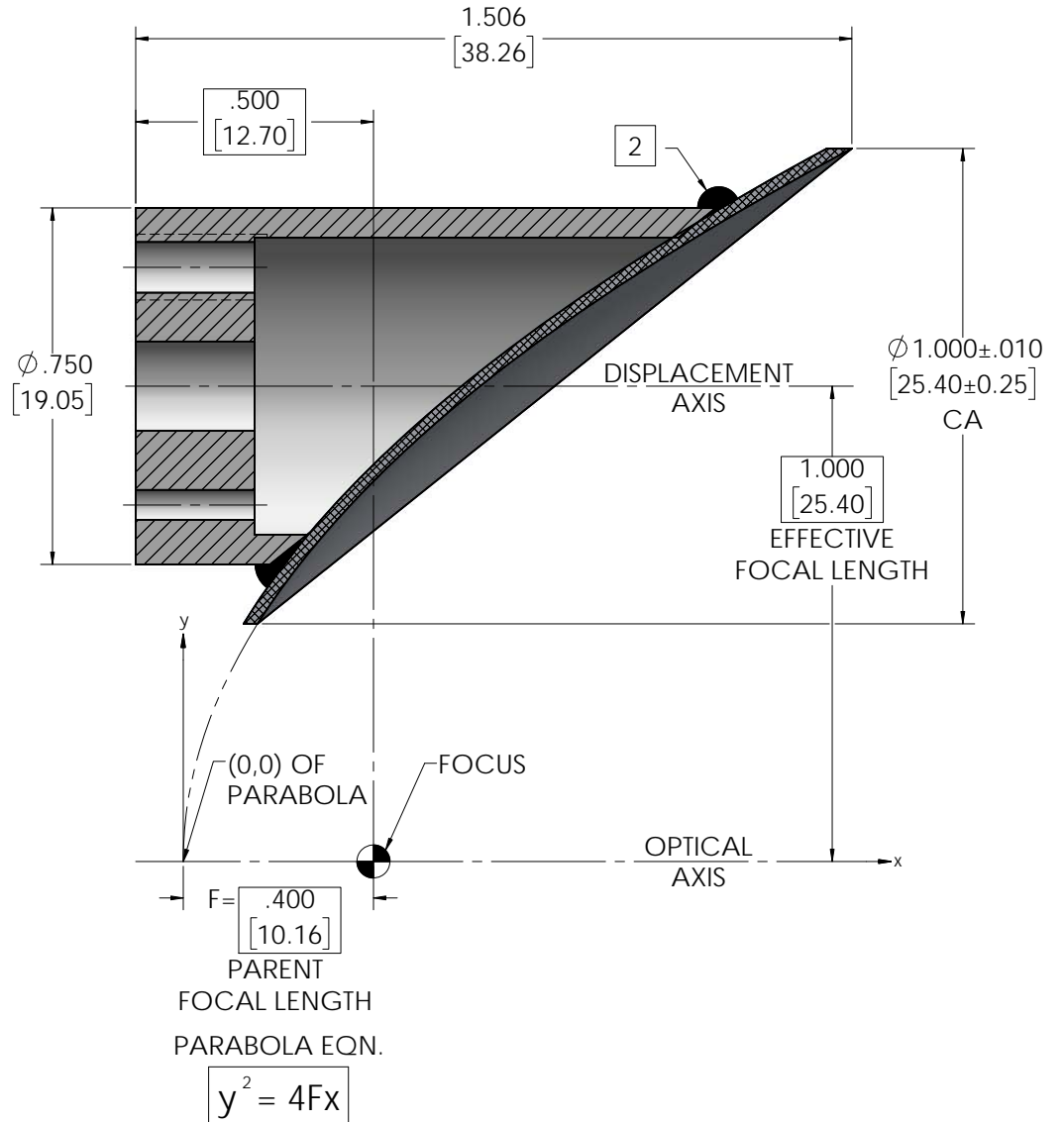
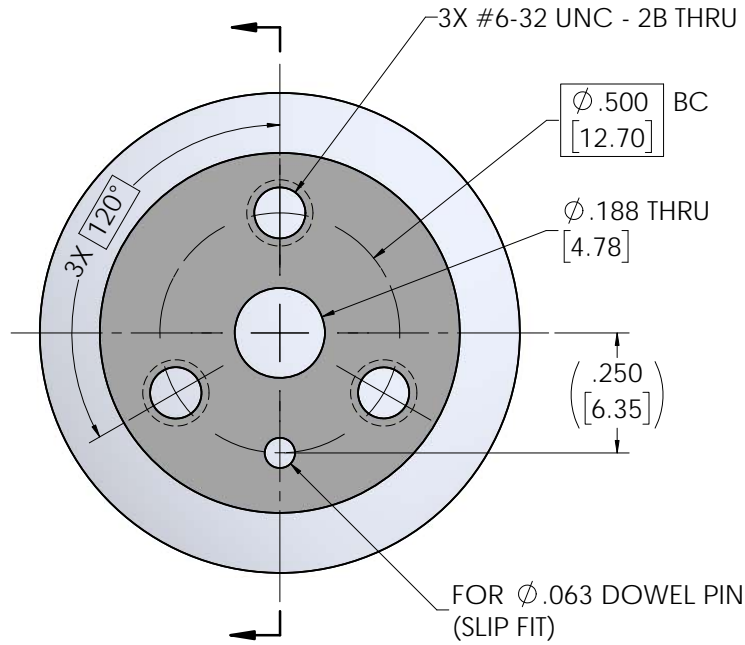

OPTIONAL ACCESSORY: 1046-002 (UNIVERSAL OAP ADAPTER)

UNLESS OTHERWISE SPECIFIED DIMENSIONS ARE IN INCHES [mm] GD&T PER ASME Y14.5-2009 DO NOT SCALE DRAWING		CONTRACT NO. 87-OAP10		optiforms® 42310 WINCHESTER RD. TEMECULA, CA 92590 WWW.OPTIFORMS.COM	
TOLERANCES		DRAWN JMK	DATE 09/21/16	OFF-AXIS ASSY, PARABOLIC OAP10 SEGMENT	
FRACTIONS ± 1/16	DECIMALS .XXX ± .02	CHECKED	DATE	SIZE C	CAGE CODE 0Y1Y4
ANGLES ± 1/2°	.XXX ± .005	ENGR KMT	DATE 09/21/16	DWG. NO. OAP10-0000-XXXX	REV A
SURFACE ROUGHNESS √ 015 MAX DEBURR SHARP EDGES & HOLES RING 015 MAX CHAMFER THREADS 01 PAST ROOT DIAMETER		MATERIAL SEE NOTE 3		SCALE 5:1	WT (REF) 0.03
THIRD ANGLE PROJECTION		FINISH N/A		CAD NO. OAP10	SHEET 1 OF 1