

NOTES: UNLESS OTHERWISE SPECIFIED

- 1 ELECTROFORM REFLECTOR FROM MASTER TOOL WITH SPECULAR SURFACE QUALITY OF 80-50 SCRATCH-DIG PER MIL-PRF-13830B.
- 2 NOMINAL THICKNESS (T) MAY VARY ± T/4 WITHIN .25 OF EDGES.
- 3 REFLECTIVE SURFACE COATING TO BE SEPARATELY SPECIFIED.

REVISIONS			
REV	DESCRIPTION	DATE	APPROVED
Ø	INITIAL DRAWING RELEASE	09/15/10	SJM
A	UPDATED DRAWING FORMAT	07/27/17	JPH
B	ADDED E50-0300	09/26/19	JPH

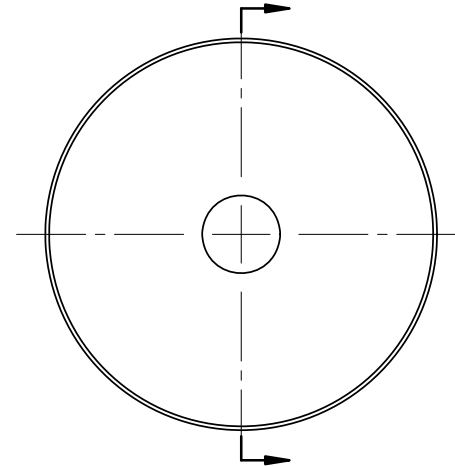
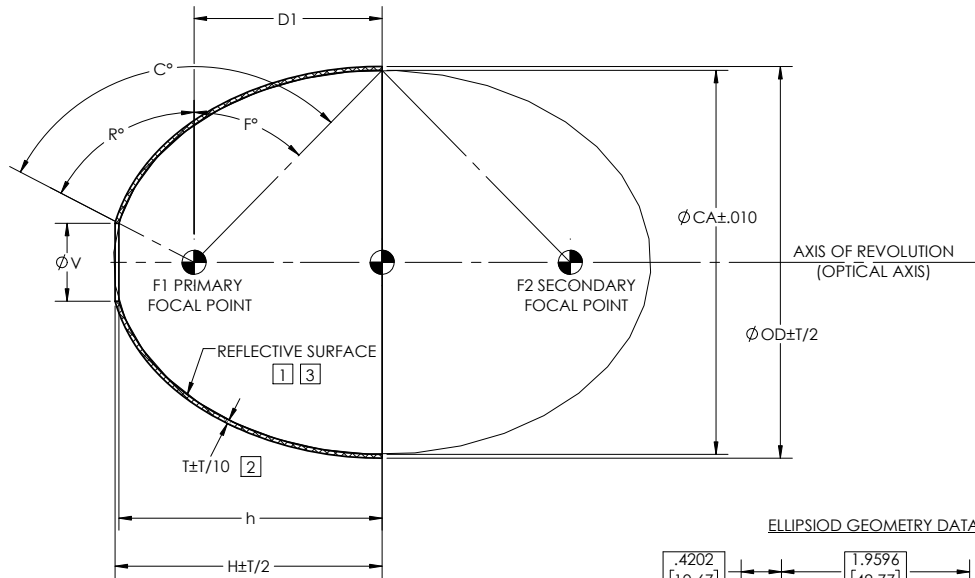

ELLIPSIOD GEOMETRY DATA

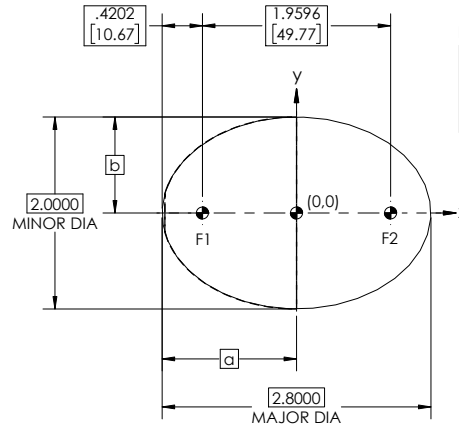

ELLIPSE EQN.
 $\frac{x^2}{a^2} + \frac{y^2}{b^2} = 1$
 $a = 1.4000$
 $b = 1.0000$

DASH NO.	CA	V	OD	T	D1	H	h	R°	F°	C°	F#
E50	2.000	0.406	2.040	0.020	0.980	1.392	1.371	62.57	44.42	106.98	0.70
E50-0100	2.000	0.406	2.040	0.020	0.980	1.392	1.371	62.57	44.42	106.98	0.70
E50-0200	2.000	0.472	2.040	0.020	0.980	1.381	1.360	58.20	44.42	102.62	0.70
E50-0300	2.000	0.500	2.040	0.020	0.980	1.377	1.356	56.36	44.42	100.78	0.70

NOTE: THE "E50" DASH NO. IS THE THEORETICALLY LARGEST REFLECTOR THAT CAN BE FORMED FROM EXISTING MASTER TOOLING.

UNLESS OTHERWISE SPECIFIED DIMENSIONS ARE IN INCHES (mm) GD&T PER ASME Y14.5-2009 DO NOT SCALE DRAWING		CONTRACT NO. 14-E50		42310 WINCHESTER RD. TEMECULA, CA 92590 WWW.OPTIFORMS.COM	
DRAWN JIW	DATE 07/27/17	ELECTROFORMED NICKEL - LSSN TYPE 1		optiforms®	
CHECKED	DATE	ELECTROFORMED NICKEL - LSSN TYPE 1		REFLECTOR, ELLIPTICAL 1.96"/50mm (F1-F2)	
ENGR RRS	DATE 07/27/17	ELECTROFORMED NICKEL - LSSN TYPE 1		SIZE C	
MATERIAL		ELECTROFORMED NICKEL - LSSN TYPE 1		CAGE CODE 0Y1Y4	
FRSH		ELECTROFORMED NICKEL - LSSN TYPE 1		DWG. NO. E50	
NEXT ASSY USED ON		SCALE 2:1		REV B	
APPLICATION		SEE NOTES 1,3		SHEET 1 OF 1	